

Coax Cables Flame Retardant

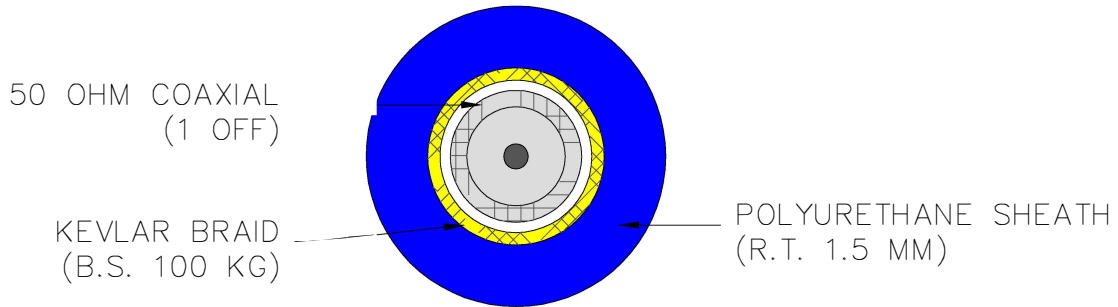

HPA Subsea supply every cable configuration. Contact us to today to discuss your cable in more detail. (Singapore)
+65 63343566 / sales@hydroproductsasia.com

Drawing No. CS 913



O.D. APPROX 7.3 MM

DESCRIPTION ONE COAXIAL (50 OHM) + KEVLAR BRAID (B.S. 100 KG)

Drawing No. CS 1971

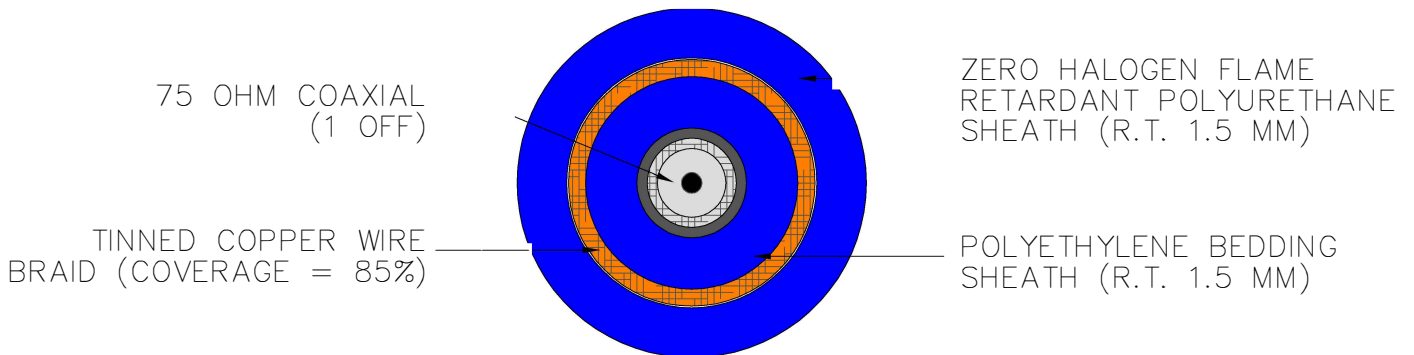

O.D. 10.2 MM ±0.5 MM

DESCRIPTION ONE COAXIAL (75 OHM) + TINNED COPPER WIRE BRAID.

Drawing No. CS 1370

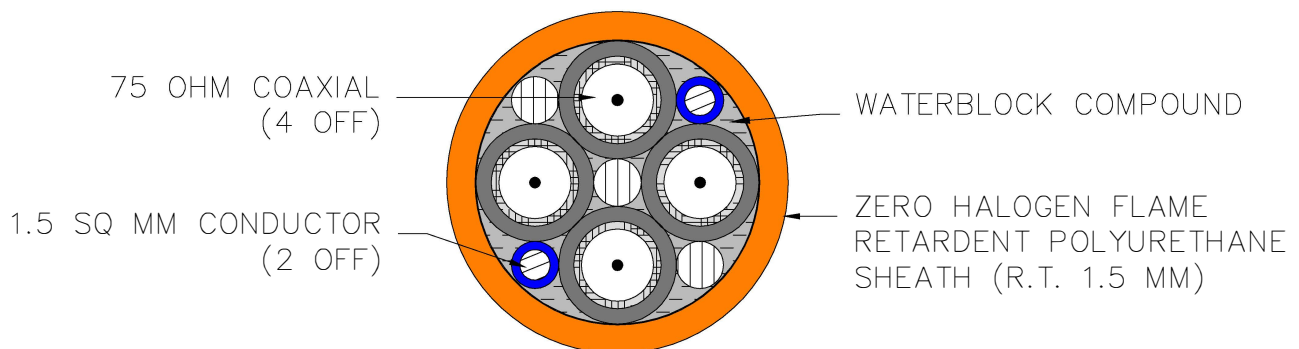

O.D. APPROX 18.0 MM

DESCRIPTION 4 COAXIALS (75 OHM) + 2 CORES (1.5 SQ MM) + WATERBLOCK COMPOUND

Coax Cables

HPA Subsea supply every cable configuration. Contact us to today to discuss your cable in more detail.
(Singapore) +65 63343566 / sales@hydroproductsasia.com



Drawing No. CS 1963

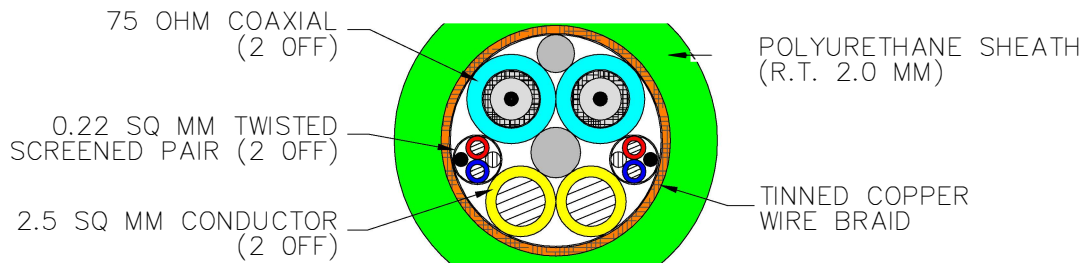

O.D. 13.8 MM ±0.5 MM

DESCRIPTION 2 CONDUCTORS (2.5 SQ MM) + 2 T.S.P.'S (0.22 SQ MM) + 2 COAXIALS (75 OHM) + T.C.W.B.

Drawing No. CS 1339

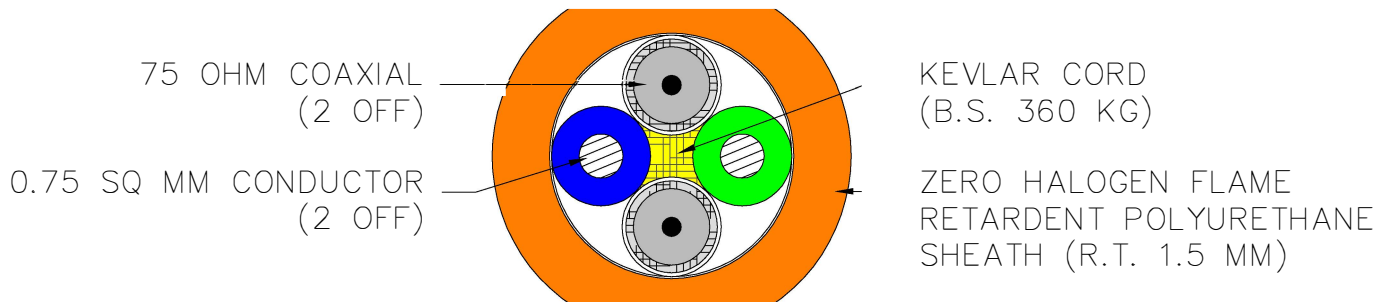

O.D. APPROX 9.4 MM

DESCRIPTION 2 CORES (0.75 SQ MM) + 2 COAXIALS (75 OHM) + KEVLAR CORD (B.S. 360 KG)

Drawing No. CS 1920

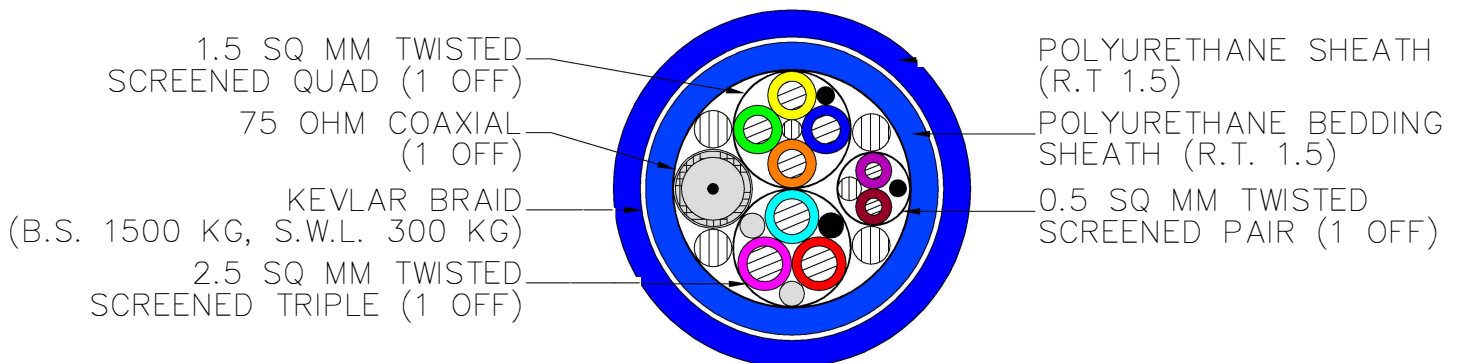

DESCRIPTION ONE TWISTED SCREENED QUAD (1.5 SQ MM) + ONE COAXIAL (75 OHM) + ONE TWISTED SCREENED TRIPLE (2.5 SQ MM) + ONE TWISTED SCREENED PAIR (0.5 SQ MM) + KEVLAR BRAID (B.S.1500 KG)



HPA Subsea supply every cable configuration, contact us today to discuss your cable in detail



Subsea connectivity products and solutions

A broad range of standard and bespoke engineered products for subsea projects

[read more](#)

Contact

HPA Subsea

12 Woodlands Square

#09-72 Woods Square, Tower 1

Singapore 737715

Tel. +65 63343566

sales@hydroproductsasia.com

<https://www.hydroproductsasia.com>